

Bedienungsanleitung

Scale Rumpf MD500D

450er Größe



1. INTRODUCTION

Thank you for buying Roban Model products. The 600 size MD500D/E scale fuselage is designed as an easy to use product. Please read the manual carefully before assembling the model, and follow all precautions and recommendations located within the manual. Be sure to retain the manual for future reference, routine maintenance and tuning. The scale fuselage is designed for T-REX 600 Helicopter series use. You can easily put it on your T-REX 600 for new clothing.

Important Note

Roban Model R/C Helicopters are advanced, high-performance devices, built incorporating the latest technologies. They are not intended as toys, and improper use can potentially lead to serious injury, or even fatal accidents. We implore you to read this manual thoroughly before operating these models. Safety should be your utmost priority - not just your own, but also that of others and your surroundings when piloting Roban Model products.

Liability Disclaimer:

The manufacturer and the seller cannot accept liability for the operation or misuse of this product. Roban Model R/C helicopters are intended to be used exclusively by experienced adults in legally sanctioned flying fields. Once sold, we cannot monitor or control the product's operation or usage.

Operation Guidelines:

Upon assembly of the scale fuselage, the weight and complexity of the structure will increase. To mitigate risk of accidents and damages, we advise against attempting 3D flights.

Skill Requirements:

The operation of R/C products necessitates a certain level of skill and familiarity. Any damages or dissatisfaction resulting from accidents, modifications, or operational mishaps are not covered under any warranty. Consequently, such products cannot be returned for repair or if you experience problems during operation or maintenance.

2. OPERATIONAL GUIDELINES FOR SAFETY IN USING R/C AIRCRAFT MODELS

Safety Zone:

Prioritize the safety of others by operating R/C aircraft models in isolated areas, free of bystanders. Avoid piloting these models near residential zones or large groups of people.

Operational Risks:

Be aware that R/C aircraft models are susceptible to accidents, malfunctions, and crashes. These may result from a range of factors such as inadequate maintenance, pilot errors, or radio interference. Understanding these risks is crucial for safe operation.

Pilot Responsibility:

Pilots bear the sole responsibility for any damage or injuries that may occur during operation or as a result of using R/C aircraft models. By undertaking the control of these devices, you accept accountability for your actions and their possible consequences. Always aim for caution and responsible handling to minimize any potential risks.

3. CONTENTS OF KIT

Please check the contents of the kit prior to installation.

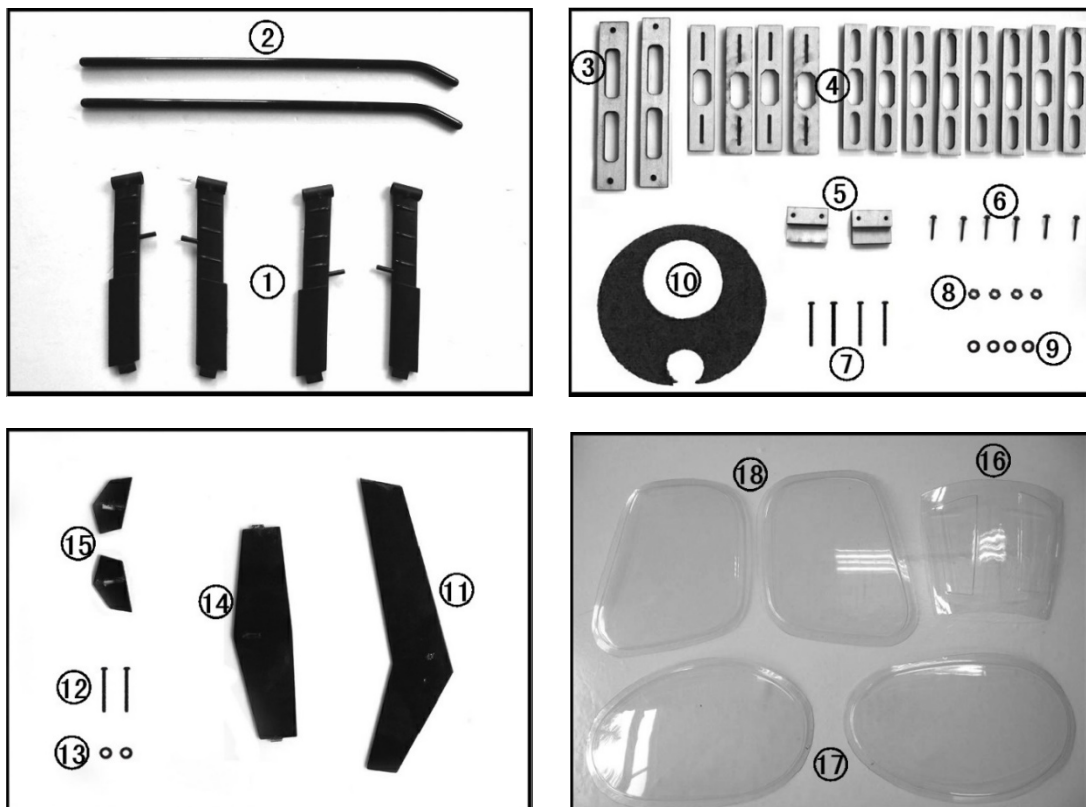

CONTENTS

Item No.	Description	Quantity
1	Landing gear struts	x2
2	Landing gear skids	x2
3	Washer 3x12x70	x2
4	Washer 3x12x51	x12
5	Mounting bracket	x2
6	Screw A2x10	x6
7	Screw M2x24	x4
8	Washer M2	x4
9	Nut M2	x4
10	EVA rear rubber	x1
11	Tail fin	x1
12	Screw M2x18	x2
13	Washer M2	x2
14	Horizontal tail	x1
15	Vertical tail	x2
16	Upper washer	x2
17	Front washer	x2
18	Rear washer	x2

REQUIRED TOOLS / CONSUMABLES

Tool No.	Tool/Consumable
1	Hobby knife
2	Allen wrench
3	Phillips screwdriver
4	File
5	Side cutters
6	Silicone adhesive
7	Super glue
8	2K Epoxy glue
9	Fine sandpaper
10	Scissors

4. INSTALLATION

4.1 Attach the landing gear struts using epoxy adhesive from the inside as shown.

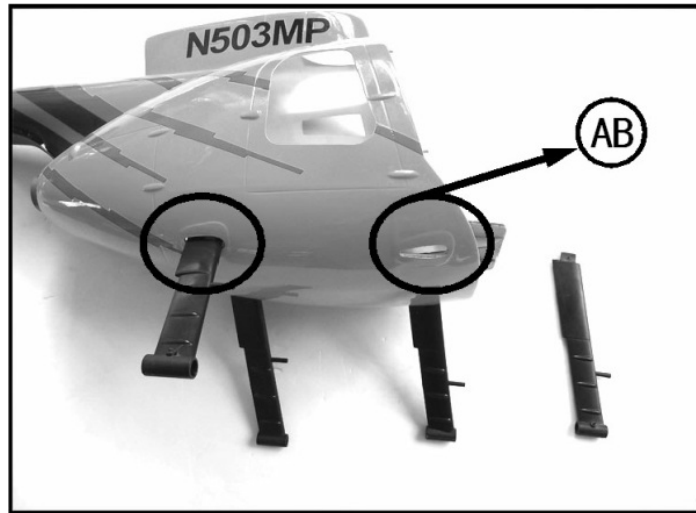

4.2 Assemble the skids as shown and glue them together.

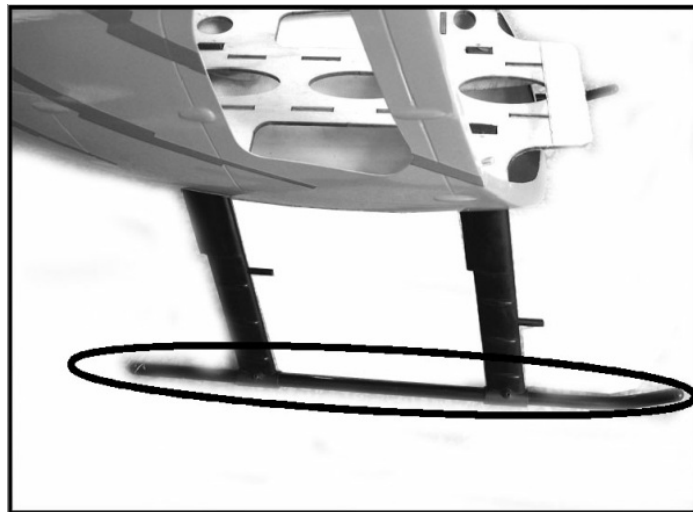

4.3 Remove any excess plastic with a hobby knife.



4.4 Glue the washers together as shown.

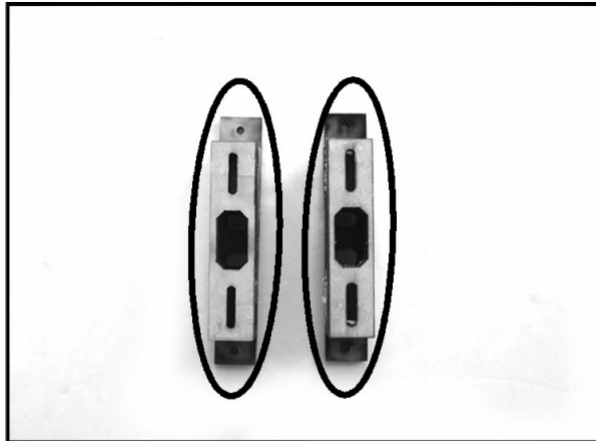

4.5 Install the mounting bracket as shown with 4 pieces of Screw A2x10.

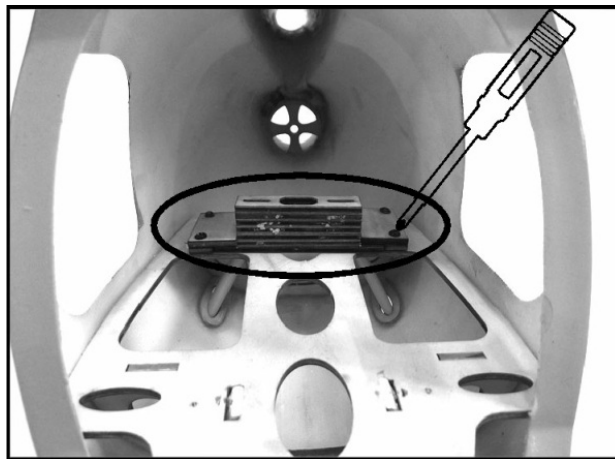

4.6 Remove the tail rotor from the mechanism.

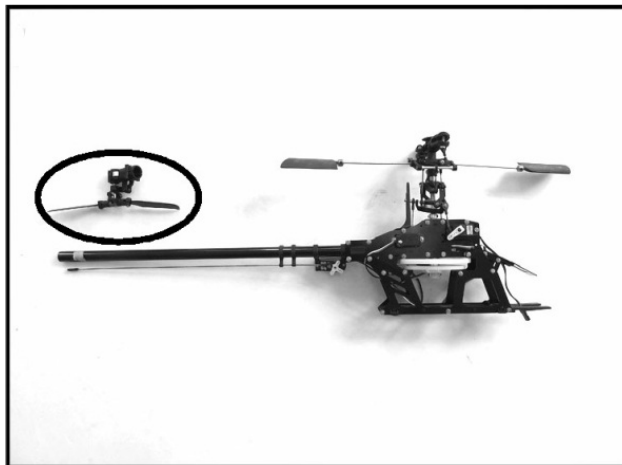

Note: The rear stack of washers is fixed to the mechanism. When installing the mechanism, this is pushed into the bracket since the screws are very difficult to access once the mechanism is installed. Make sure that the brackets are mounted correctly to allow the stack of washers to be inserted.

4.7 Install the washers.

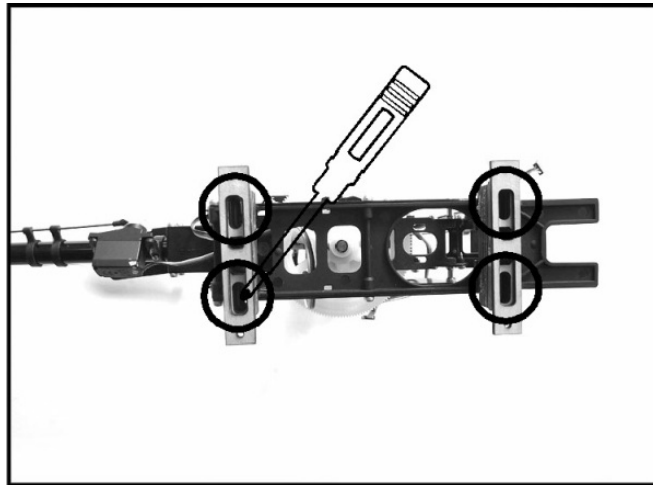

4.8 Insert the mechanism.

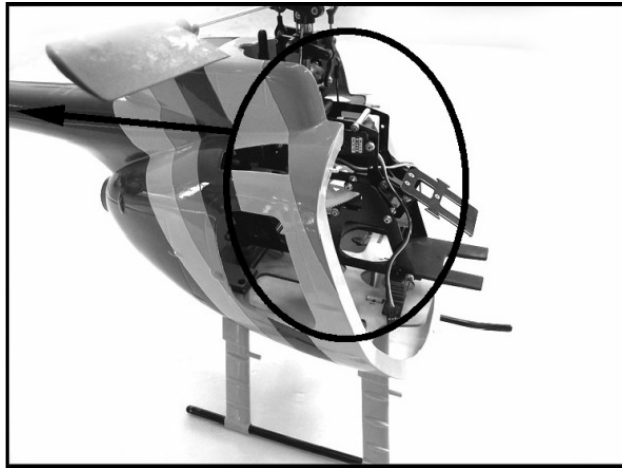

4.9 The wooden adapter must be inserted into the detent.



4.10 Secure the front section with 2 pieces of Screw A2x10 as shown.

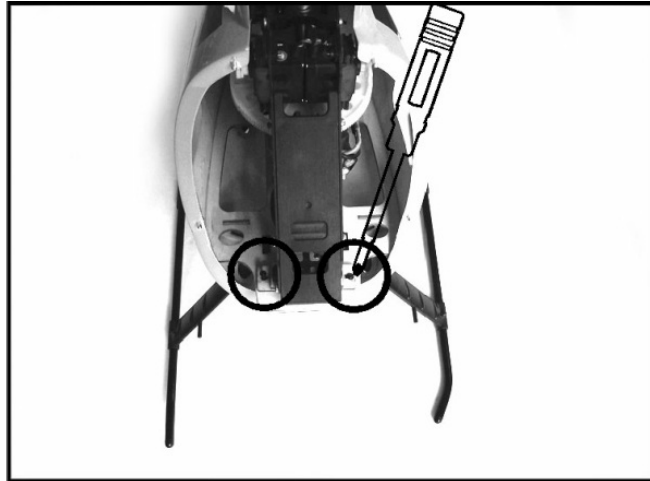

4.11 Install the rear rubber.

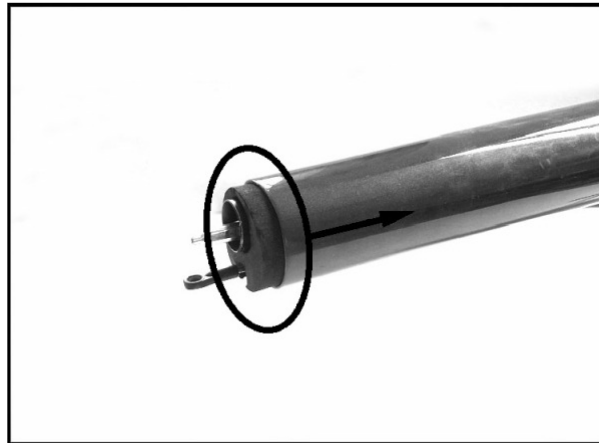

4.12 Install the tail rotor.

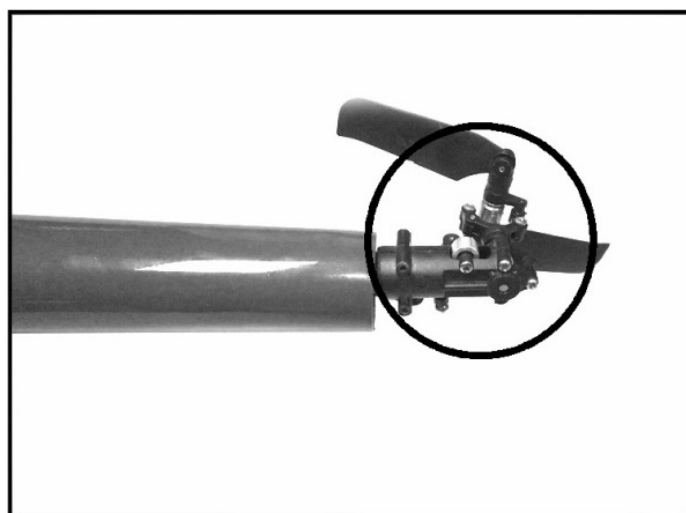

4.13 Install the tail fin with a screw.

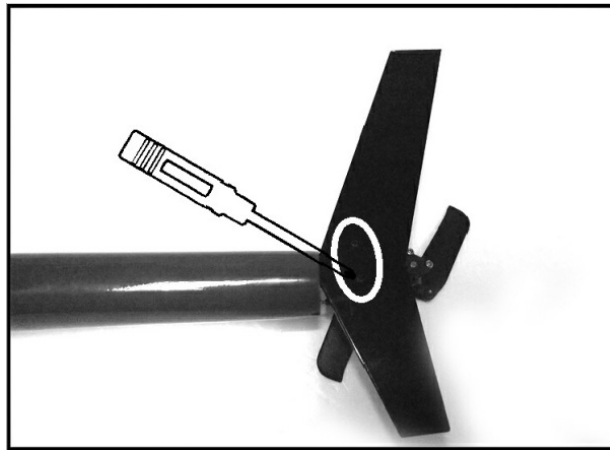



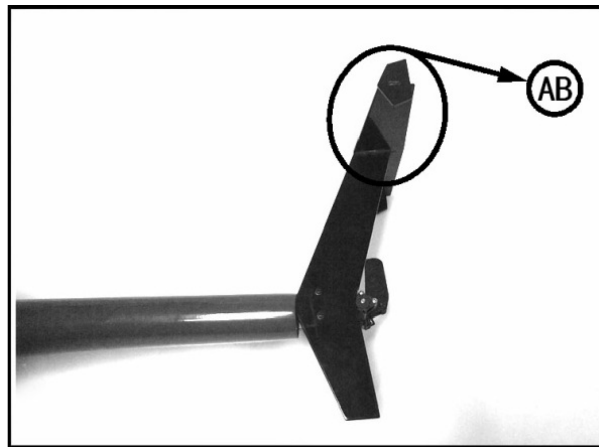

4.14 Glue the tail unit with epoxy resin adhesive as shown.



5. SPAREPART LIST

HSB- MD450GJB-E	MD450EPJ001		450MD500E 前 头	450 MD500E canopy
	MD450EPJ002		450MD500E 侧 窗	450 MD500E window set
	MD450EPJ003		450MD500E 平 垂尾	450 MD500E tail fins

	MD450EPJ004		450MD500E 脚架组	450 MD500E landing gear
	MD450EPJ005		450MD500E 固定件	450 MD500E mounting hardware
	MD450EPJ006		450MD500E 水印	450 MD500E decals
HSB-MD450MG-D	MD450DPJ001		450MD500D 前头	450 MD500D canopy
	MD450DPJ002		450MD500D 侧窗	450 MD500D window set
	MD450DPJ003		450MD500D 平垂尾	450 MD500D tail fins
	MD450DPJ004		450MD500D 脚架组	450 MD500D landing gear
	MD450DPJ005		450MD500D 固定件	450 MD500D mounting hardware
	MD450DPJ006		450MD500D 水印	450 MD500D decals
	MD450DPJ007		450 小鸟武器组	450 MD500D weapon set

6. FULLY ASSEMBLED FUSELAGE



Align TREX450 und baugleiche Mechaniken

Specifications:

Length: 695mm

Height: 365mm

Width: 158mm

Weight: 330g

Suitable for Align TREX450ESP/EFL/PRO and derivatives

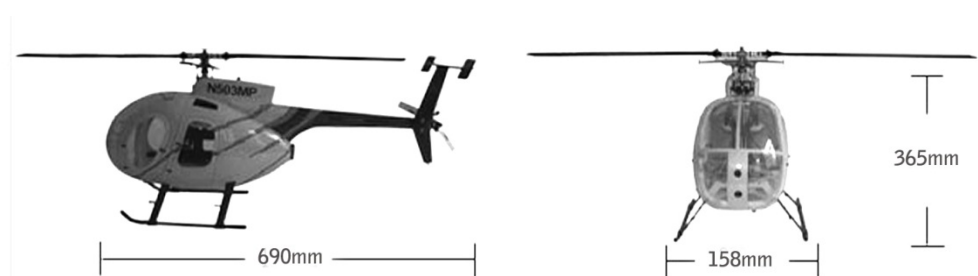

We wish you a lot of fun with the fuselage!

ROBAN

Copyright 2024 – www.robamodel.com